



At Home Learning Resources

Grade 2 - Week 5

LOWELL PUBLIC SCHOOLS

Grab and Go Meals

*Available for Lowell Public Schools Students
on Weekdays While School is Closed*

Butler (12:45 - 1:30pm) 1140 Gorham St.	Murkland (12:45 - 1:15pm) 350 Adams St.
Greenhalge (10:30 - 11:15am) 149 Ennell St.	Pawtucketville (12 - 12:30pm) 425 West Meadow Rd.
Lincoln (1:30 - 2pm) 300 Chelmsford St.	Robinson (11:30 - 11:45am) 110 June St.
Moody (12 - 12:30pm) 158 Rogers St.	STEM Academy (10:30am - 1pm) 43 Highland St. <i>Meal service at South St. entrance</i>
NEW: Morey (12 - 12:30pm) 130 Pine St.	NEW: Stoklosa (11 - 11:30am) 560 Broadway St.
NEW: Westminster Village Apartments (12.45 - 1:15pm) 1307 Pawtucket Blvd.	

When you pick up that day's lunch, you can also pick up breakfast for the next morning.

Use this chart to help
you read some poems.
You can read or perform
them for your family.

Reading Poetry Like a Poet



As I read this
writing, can I make a
picture in my mind?



Does this writing
help me look at the
world in new ways?

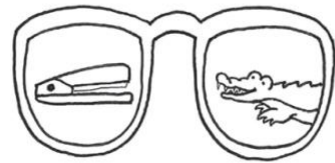

Does this writing
give me a certain
feeling or make me
think or question?



Does this poem
have music?



Catch A Little Rhyme

By Eve Merriam

Once upon a time
I caught a little rhyme

I set it on the floor
but it ran right out the door

I chased it on my bicycle
but it melted to an icicle

I scooped it up in my hat
but it turned into a cat

I caught it by the tail
but it stretched into a whale

I followed it in a boat
but it changed into a goat

When I fed it tin and paper
it became a tall skyscraper

Then it grew into a kite
and flew far out of sight...

Keep A Poem In Your Pocket

By Beatrice Schenk de Regniers

Keep a poem in your pocket
And a picture in your head
And you'll never feel lonely
At night when you're in bed.

The little poem will sing to you
The little picture bring to you
A dozen dreams to dance to you
At night when you're in bed.

So - -

Keep a picture in your pocket
And a poem in your head
And you'll never feel lonely
At night when you're in bed.

My Dog, He is an Ugly Dog
by Jack Prelutsky

My dog, he is an ugly dog,
He's put together wrong,
His legs are much too short for him,
His ears are much too long.
My dog, he is a scruffy dog,
He's missing clumps of hair,
His face is quite ridiculous,
His tail is scarcely there.

My dog, he is a dingy dog,
His fur is full of fleas,
He sometimes smells like dirty socks,
He sometimes smells like cheese.
My dog, he is a noisy dog,
He's hardly ever still,
He barks at almost anything,
His voice is loud and shrill.

My dog, he is a stupid dog,
His mind is slow and thick,
He's never learned to catch a ball,
He cannot fetch a stick.
My dog, he is a greedy dog,
He eats enough for three,
His belly bulges to the ground,
He is the dog for me.

If I Were In Charge of the World

By: Judith Viorst

If I were in charge of the world
I'd cancel oatmeal,
Monday mornings,
Allergy shots, and also
Sara Steinberg

If I were in charge of the world
There'd be brighter night lights,
Healthier hamsters, and
Basketball baskets forty eight inches lower.

If I were in charge of the world
You wouldn't have lonely,
You wouldn't have clean,
You wouldn't have bedtimes,
Or "Don't punch your sister."
You wouldn't even have sisters.

If I were in charge of the world
A chocolate sundae with whipped cream and nuts
would be a vegetable
All 007 movies would be G
And a person who sometimes forgot to brush,
And sometimes forgot to flush,
Would still be allowed to be
In charge of the world.

Use this chart to help you
write your own poems.

Strategies Poets Use to Write Poems



Poets find a topic
that gives them
a big feeling.



Poets find a small
moment, detail, or
object that holds
the big feeling.



Poets look with
poets' eyes and see
this ordinary thing
in a new way.



Poets write about it,
experimenting with
line breaks.



FILL these FRAMES
With YOUR OWN Poem
MASTERPIECES

(DON'T FORGET TO TITLE THEM!)

Poems by: _____

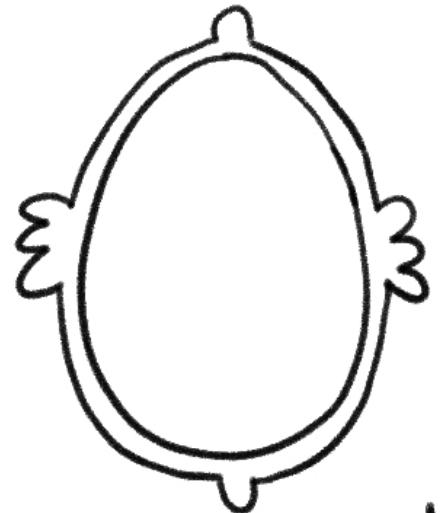
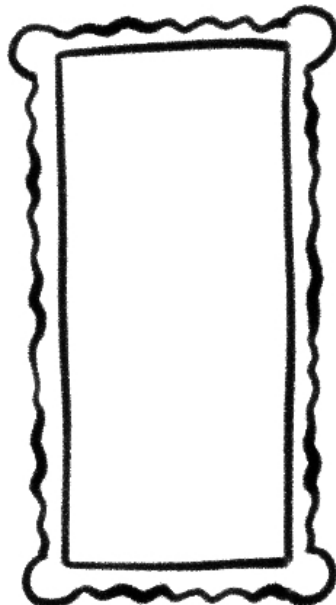
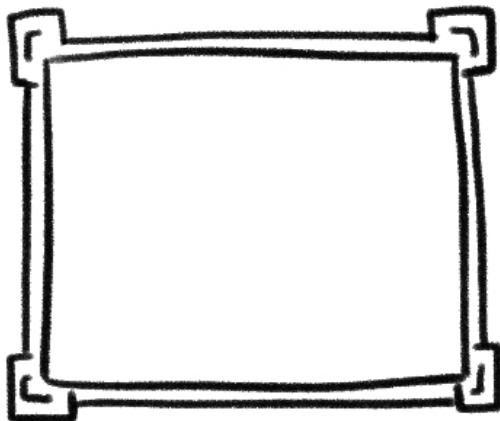
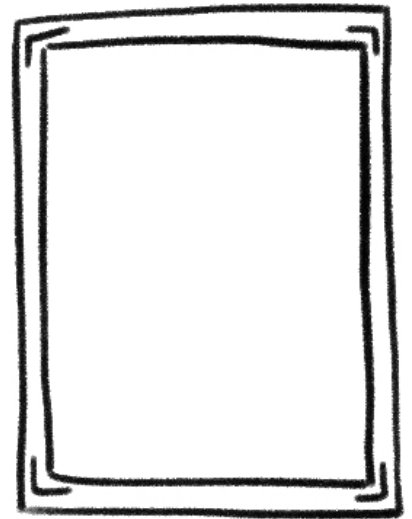
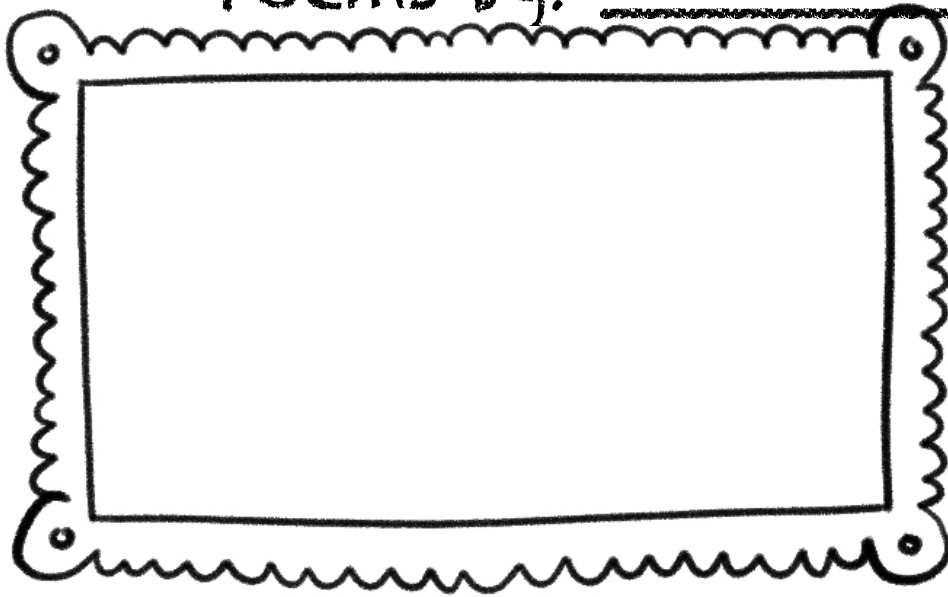

JARRETT!!

Explore different ways to understand finding the value of three-digit numbers.

Amir plays a board game that uses play money. He wins 1 tens bill, 2 hundreds bills, and 3 ones bills. What is the total value of the bills Amir wins?

PICTURE IT

You can use play money to model the problem.



PICTURE IT

You can make a quick drawing to show hundreds, tens, and ones.



MODEL IT

You can show hundreds, tens, and ones in a chart.

Hundreds	Tens	Ones
2	1	3

CONNECT IT

Now you will use the problem from the previous page to help you find the value of three-digit numbers.

- 1 Look at the models on the previous page. How many hundreds, tens, and ones are there?

..... hundreds ten ones

- 2 What is the value of the hundreds bills? dollars

What is the value of the tens bill? dollars

What is the value of the ones bills? dollars

- 3 Write an equation to find the total value of all the bills.

..... + + = dollars

- 4 Amir wins 2 more tens bills. Tell how to write the new total value of Amir's play money.

5 REFLECT

Look back at your **Try It**, strategies by classmates, and **Picture Its** and **Model It**. Which models or strategies do you like best for finding the value of three-digit numbers? Explain.

.....

.....

.....

APPLY IT

Use what you just learned to solve these problems.

- 6 What is another way to show each number? Draw lines to connect each number to its expanded form.

392

329

239

$300 + 20 + 9$

$200 + 30 + 9$

$300 + 90 + 2$

- 7 Tia is playing a ring toss game to win tokens. She wins 3 hundreds tokens, 4 tens tokens, and 7 ones tokens. What is another way to write the total value of the tokens Tia wins? Show your work.



Solution

- 8 When does the digit 8 mean eighty? When does the digit 8 mean eight hundred? When does the digit 8 mean just eight?

Practice Finding the Value of Three-Digit Numbers

Study the Example showing three-digit numbers in different ways. Then solve problems 1–6.

EXAMPLE

In a game, Jan pays money to the bank. She pays 2 hundreds bills, 4 tens bills, and 5 ones bills. What is the total value of the bills Jan pays?

Make a quick drawing.

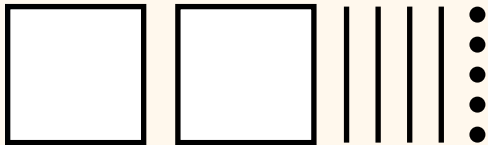

Use a chart.

Hundreds	Tens	Ones
2	4	5

Write an equation.

$$200 + 40 + 5 = 245 \text{ dollars}$$

Bob plays a board game that uses play money. He wins 3 hundreds bills, 7 tens bills, and 7 ones bills.

1 How many hundreds, tens, and ones are there?

..... hundreds tens ones

2 Write the total value of the bills using expanded form.

..... + + =

3 What is the total value of the bills Bob wins?

..... dollars

Vocabulary

expanded form a way a number is written to show the place value of each digit.

- 4 Ali plays a board game that uses play money. He wins 8 hundreds bills and 6 ones bills. What is the total value of the bills Ali wins? Fill in the chart and then write the answer. Show your work.

Hundreds	Tens	Ones



Solution

- 5 Audra has 533 comic books. Write or draw to show this number in a different way.
- 6 What is another way to show each number? Draw lines to connect each number to its expanded form.

784

874

748

$800 + 70 + 4$

$700 + 80 + 4$

$700 + 40 + 8$

Practice Writing Three-Digit Numbers

Study the Example showing how to write a three-digit number in different ways. Then solve problems 1–6.

EXAMPLE

In a video game, Eduardo scores 753 points.

Write this number three different ways.

Using only digits: 753

Using expanded form: $700 + 50 + 3$

Using words:

seven hundred + fifty + three =
seven hundred fifty-three



Use the chart below for problems 1–3.

Hundreds	Tens	Ones
3	2	2

1 Write the number using only digits.

2 Write the number in expanded form.

..... + +

3 Write the number using words.

- 4 There are 225 building bricks in a box.
How would you write 225 in expanded form?
Fill in the chart and then write the answer.

Hundreds	Tens	Ones

Solution

- 5 Helen counts her crayons. She writes the number as $700 + 3$.
Write the number using only digits.

Solution

Write the number using only words.

Solution

- 6 What are other ways to show each number?
Look at each number shown using only digits.
Draw a line to the expanded form and to the words for each number.

$500 + 60 + 1$ **651** six hundred fifteen

$600 + 10 + 5$ **615** five hundred sixty-one

$600 + 50 + 1$ **561** six hundred fifty-one

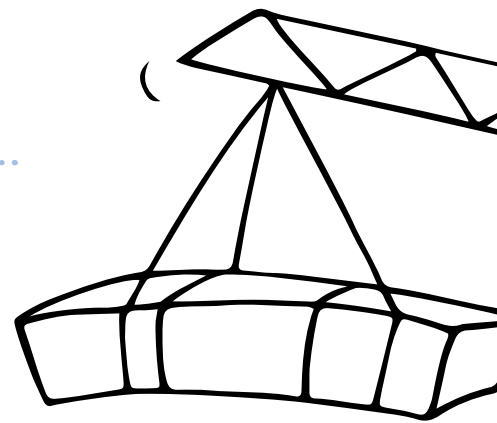

Refine Comparing Three-Digit Numbers

Complete the Example below. Then solve problems 1–3.

EXAMPLE

Yen packs 250 oranges in a box. Gia packs 25 bags of oranges with 10 oranges in each bag. Who packs more oranges?

Look at how you can find the number of oranges Gia packs.

$$25 \text{ bags with } 10 \text{ in each bag} = 25 \text{ tens}$$

$$25 \text{ tens} = 250$$

$$250 \text{ oranges in a box} = 250$$

Solution

APPLY IT

- 1 Write the number of hundreds and tens for each score in the table. Circle the names of the two players with the greatest scores.

Player	Score	Hundreds	Tens
Eden	92		
Sarita	233		
Paul	213		
Chen	236		

Remember to look at the hundreds place first.



- 2 Bella rides her bike 122 miles. Ariel rides her bike 126 miles. Who rides fewer miles? Show your work.

Are you looking for the lesser or greater number?



Solution

- 3 Jill and Iman each write a three-digit number.

Jill's number: 305

Iman's number: 3 hundreds 5 tens

Which correctly compares Jill's and Iman's numbers?

- (A) $305 < 305$
- (B) $305 > 350$
- (C) $350 > 305$
- (D) $350 < 305$

Dan chose (B) as the answer. How did Dan get his answer?

What number is the same as 3 hundreds 5 tens?

Practice Comparing Three-Digit Numbers

- 1 In one week, Glen reads for 317 minutes. Fran reads for 372 minutes. Who reads for more minutes? Tell how you know. Show your work.

Are you looking for the lesser or greater number?



Solution

- 2 Choose *True* or *False* to tell if the comparison is correct.

	True	False
$131 < 119$	(A)	(B)
$605 = 650$	(C)	(D)
$454 > 451$	(E)	(F)
$709 < 722$	(G)	(H)

Which place value should you compare first?

- 3 Marcy has 237 stickers. Then she gives some stickers away. How many stickers could Marcy have now?

- (A) 239 (B) 198
 (C) 229 (D) 323
 (E) 237 (F) 207

Does Marcy have more than or fewer than 237 stickers now?

- 4 Which comparison is true?
- A $420 < 4 \text{ hundreds } 3 \text{ ones}$
 - B $370 > 407$
 - C $6 \text{ hundreds } 4 \text{ tens} < 640$
 - D $919 < 991$

Deb chose A. How did Deb get her answer?

You can rewrite the numbers that are shown as tens and ones.



- 5 Use the digits 5, 2, and 9 to make the least three-digit number that you can. Explain how you find your answer.

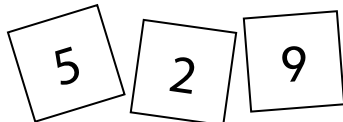

I think I will choose the digit for the hundreds place first.

- 6 Use the digits from problem 5 to make the greatest three-digit number that you can. Write your number below.

.....

Which is the greatest digit?

Seed Toys



What Is This Activity?

Plants can't travel, so how do they spread their seeds? Families will make and test toys that model two amazing ways: Seed pods that explode and those that float and twirl like a helicopter!

pbskids.org/plumlanding/parents

Curriculum Topics

plants, life cycles, adaptation, human impact

Activity Type

outdoor (all weather except rain and heavy snow)

Group Size

whole group, small groups

Activity Time

40-60 minutes

Materials

- Assembled Seed Blaster and Seed Copter for demonstration (see handouts)
- Optional: Pea pod or other seed pod (see "Seed Blaster Activity" step 1 for plant names) and a two-winged seed such as a maple seed

One per family member:

- "Seed Blaster" handout
- Small balloon
- Toilet paper tube or one half of a paper towel tube
- About half a cup of birdseed, small dried peas, crushed pasta bits, or other small light objects
- "Seed Copter" handout
- A small paper clip
- Scissors (shared)
- Roll of masking or packing tape (shared)
- Optional: "Explore Plants Around You" handout (one per family)

Next Generation Science Standards

Disciplinary Core Ideas

- LS1.A: Structure and Function
- LS2.A: Interdependent Relationships in Ecosystems
- PS2.A: Forces and Motion

Science and Engineering Practices

- Asking Questions and Defining Problems
- Planning and Carrying Out Investigations
- Obtaining, Evaluating, and Communicating Information
- Analyzing and Interpreting Data

Crosscutting Concepts

- Patterns
- Cause and Effect: Mechanism and Prediction

Learning Goals

Big Science Idea:

- Plants can't move on their own. They depend on wind, water, animals, and explosive force to take their seeds to new places where they can sprout and grow.

Skills kids will use to investigate it:

- Communicate information about the plant life cycle
- Model and test how seed pods spread their seeds (exploding, floating in the air); communicate why they do so
- Measure distances seeds need to travel to find soil
- Discuss a problem: Cities and towns with a lot of pavement provide fewer places for seeds to sprout and grow

How Do You Get Ready?

- Read the activity and gather the materials.
- Scout out a green space, such as a city or town park or your program yard, with at least a few trees or other plants.
- Troubleshoot safety concerns (traffic, poison ivy, sharp objects, etc.).
- Make one copy for each family member of the "Seed Blaster" and "Seed Copter" handouts. Make extra copies of the "Seed Copter" handouts for families to take home.

- Make a Seed Blaster and a Seed Copter to use for demonstration (see handouts).
- If you don't plan to show the "Plant Your Socks" video that is paired with this activity on the website, watch it ahead of time and jot down concepts to share with families during the activity.

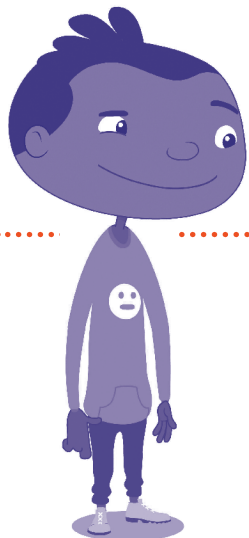

Warm-up (5-10 minutes)

(Science Skills: Communicate information about the plant life cycle)

Bossy Gardener Game

- 1. Play the Bossy Gardener.** The families are your “Plants” and must obey your commands. Demonstrate each command and ask families to copy your actions:
 - **Plant the Seed:** Drop to the ground and do a push-up.
 - **Sprout the Seed:** Jump as high as you can, hands in the air. (Explain the verb sprout: When a seed begins to grow into a young plant.)
 - **Make a Flower:** Do a jumping jack.
 - **Make New Seeds:** Find a partner, hold both hands, and spin around together.
- 2. Shout the first three commands in random order.** At each command, if anyone does the wrong action or doesn't do anything, everyone “Makes New Seeds”!
- 3. The goal is to say 10 commands in a row without anyone making a mistake.** (Note: You may or may not reach this goal!)

Activity

Seed Blaster (20-25 minutes)

(Science Skills: Model and test how seed pods explode to spread their seeds)

- 1. Ask families if anyone has heard of these plants:** Pansies, geraniums, California poppies, touch-me-nots (impatiens), violets, lilacs, lupines, peas, okra, squirting cucumbers, or firecracker plants. *What might they have in common?* (The names of the last two provide a hint.)
- 2. Explain that these plants all have seed pods that explode!** Point out that some seeds are covered—meaning they grow inside a case, called a pod, or inside a fruit. If you have a pea pod or other seed pod, open it and pass it around.
- 3. Wonder aloud:** *How do seed pods explode? Why do they explode?* Let those questions hang as you **demonstrate a Seed Blaster**.
- 4. Ask:** *What does the “balloon” do?* Explain that the walls of the pod tighten as they dry up, building up tension. A hot day or a touch makes the pods spring open—with force! The balloon causes the “seeds” to explode out.
- 5. Have families act out exploding like a seed pod.**
- 6. Pass out on the “Seed Blaster” handout and review directions with families.**
- 7. Pass out the materials:** balloons, tubes, scissors, tape, and seeds.
- 8. Ask adults and older siblings to make their own Seed Blaster and to help younger children make theirs,** using the instructions on the handout. Walk around the groups to ask and answer questions and encourage families.

Why Seeds Explode!

The walls of the seed pods tighten as they dry up, building up tension. A hot day or a touch makes the pods spring open—with force!



9. Hold a **Seed Blaster Contest** (see handout for directions)! Families can try to beat their own records or play against each other.

Seed Copter (10–15 minutes)

(Science Skills: Model and test seeds that float and twirl in the air)

1. **Point to a tree and ask:** *How do you think it got there? How could it spread its seeds far away?* Exploding seed pods (as in the Seed Blaster activity) are only one method out of many. Have the families to act out these seed dispersal methods (Adults may be hesitant to do some of these. That is okay):
 - Float in the wind (families pretend to float).
 - Roll on the ground (families roll five times).
 - Get carried away by water (families do three somersaults).
 - Stick to an animal's fur (families hug themselves).
 - Get eaten by an animal. Animals drop and “plant” the seeds when they poop (families fall to the ground over and over again).
2. **Demonstrate the Seed Copter. Ask families to twirl like the Copter,** with arms outstretched. **Ask:** *How does the wind feel on your arms? Does anyone know a seed that twirls like that?*
3. **Optional: Show the group the two-winged seed,** if you have one. Drop it to the ground so they can see how it twirls. Open the seed pod to reveal the seeds inside.
4. **Pass out the “Seed Copter” handout and review directions with families.** Point out the maple seed drawing, which is what the Copter models.
5. **Pass out scissors and paper clips. Ask adults and older siblings to make their own Seed Copter and to help younger children make theirs,** using the instructions on the handout.
6. **Circulate to support and encourage families.**
7. Hold a **Seed Copter contest** (see handout). Families can try to beat their own records or play against each other.
8. **If you have extra time:** Challenge families to experiment with and improve the design—the proportions, the weight, the tilt of the wings, and so on.

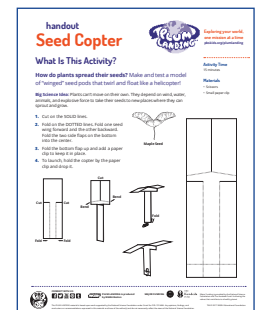
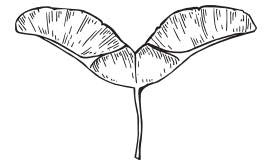

Wrap-up (5–10 minutes)

(Science Skills: Communicate why plants spread their seeds; Measure distances seed need to travel to find soil; Discuss a problem: Cities with a lot of pavement provide fewer places for seeds to sprout and grow)

Gather around a plant near pavement (if possible) and ask what kids thought of the toys. **Ask:** *How far would these plants need to fling their seeds to find open soil? How far to find soil with sunlight and room to grow? What if the seeds hit pavement or a very shaded or crowded area?*

- **Measure:** Ask families to pick a path the plant's seeds could go to get to soil and measure the distance, walking heel-to-toe. *Would their Seed Blaster or Seed Copter cover that distance?*

- **Discuss:** *Why do plants fling their seeds so far?* (Spreading lots of seeds, far away, means more of the seeds will land in good places to sprout and grow. If seeds land right next to the parent plant, they might not have enough space, light, nutrients or water to grow because the parent plant needs those resources too.)
- **Discuss a problem:** *How do city structures (sidewalks, streets, buildings) affect a seed's chances of growing?* (The city has fewer places with open soil for seeds to sprout and grow than the country. It can also have more shade because of buildings and other large objects.)
- **Encourage families to take home the “Seed Blaster” handout** and give them extra copies of the “Seed Copter” handout to repeat the activities in their neighborhoods. Point out the “Explore Some More” activities as well. If you like, **give families the “Explore Plants Around You” handout** to provide them with more ideas on how to continue investigating plants together.



Explore Some More

Seed Racer

Play this PLUM LANDING game, in which Plum explains how plants spread their seeds to new places using wind, water, and animals. Plum then challenges kids to collect a variety of seeds over a series of timed missions. Encourage kids to look for the fun facts that pop up as they play the game. Have them pay attention to how shape and other features affect how seeds travel.



VISIT pbskids.org/plumlanding/parents to find more activities, games, and videos.



CONNECT WITH US



PLUM LANDING is produced by WGBH Boston

MAJOR FUNDING



Major Funding is provided by the National Science Foundation and The Kendeda Fund: furthering the values that contribute to a healthy planet

This PLUM LANDING material is based upon work supported by the National Science Foundation under Grant No. DRL-1516466. Any opinions, findings, and conclusions or recommendations expressed in this material are those of the author(s) and do not necessarily reflect the views of the National Science Foundation.

TM/© 2017 WGBH Educational Foundation.

handout

Seed Blaster



Exploring your world,
one mission at a time
pbskids.org/plumlanding

What Is This Activity?

How do plants spread their seeds? Make and test a model of one forceful strategy: Seed pods that explode!

Big Science Idea: Plants can't move on their own. They depend on wind, water, animals, and explosive force to take their seeds to new places where they can sprout and grow.

Go Outside

How to Make a Seed Blaster

1. Tie off the neck of a deflated balloon.
2. Cut off the tip (opposite the neck) of the balloon.
3. Wrap the balloon around one end of a toilet paper tube. Be sure it's snug.
4. Tape the balloon firmly in place.

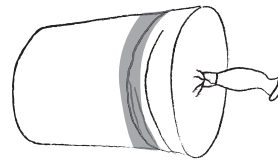
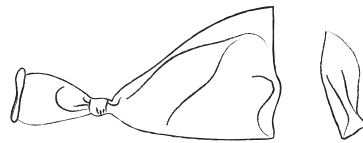

How to Test a Seed Blaster

1. Sprinkle a few seeds into the balloon.
2. Pull back the balloon as far as you can. Let go!
3. Hold a Seed Blaster Contest:
 - How far can you blast the seeds? Can you beat that record?
 - Can you jump as far as the seeds travel?
 - Can you run faster than the seeds fly?
 - How could you boost the Seed Blaster's range? (Lighter weight seeds, super stretchy balloon, blast in the direction of wind, etc.)

Activity Time

15 minutes

Materials

Per person

- Small balloon
- Toilet paper tube or paper towel tube cut in half
- Scissors
- Roll of masking or shipping tape
- About half a cup of birdseed (or small dried peas or crushed pasta bits)

Cool Fact

Some exploding seed pods can launch seeds up to 200 feet—as long as two basketball courts!

Outdoor Family Fun with Plum APP

This app gets families outdoors exploring the world. Every day, the app offers five outdoor missions to get everyone thinking and talking about nature and the science that's all around us.

Find the app and more fun resources on pbskids.org/plumlanding.

Explore Some More

Slow-Motion Explosions

If you have internet access, search for “exploding seed pods” and watch a nature video of seed pods exploding. The Smithsonian Channel has an amazing slow-motion one on YouTube, for example.



CONNECT WITH US



PLUM LANDING is produced by WGBH Boston

MAJOR FUNDING



Major Funding is provided by the National Science Foundation and The Kendeda Fund: furthering the values that contribute to a healthy planet

This PLUM LANDING material is based upon work supported by the National Science Foundation under Grant No. DRL-1516466. Any opinions, findings, and conclusions or recommendations expressed in this material are those of the author(s) and do not necessarily reflect the views of the National Science Foundation.

TM/© 2017 WGBH Educational Foundation.

handout

Seed Copter



Exploring your world,
one mission at a time
pbskids.org/plumlanding

What Is This Activity?

How do plants spread their seeds? Make and test a model of “winged” seed pods that twirl and float like a helicopter!

Big Science Idea: Plants can't move on their own. They depend on wind, water, animals, and explosive force to take their seeds to new places where they can sprout and grow.

1. Cut on the SOLID lines.
2. Fold on the DOTTED lines. Fold one seed wing forward and the other backward. Fold the two side flaps on the bottom into the center.
3. Fold the bottom flap up and add a paper clip to keep it in place.
4. To launch, hold the copter by the paper clip and drop it.

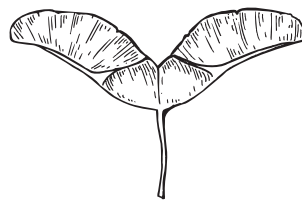

Maple Seed

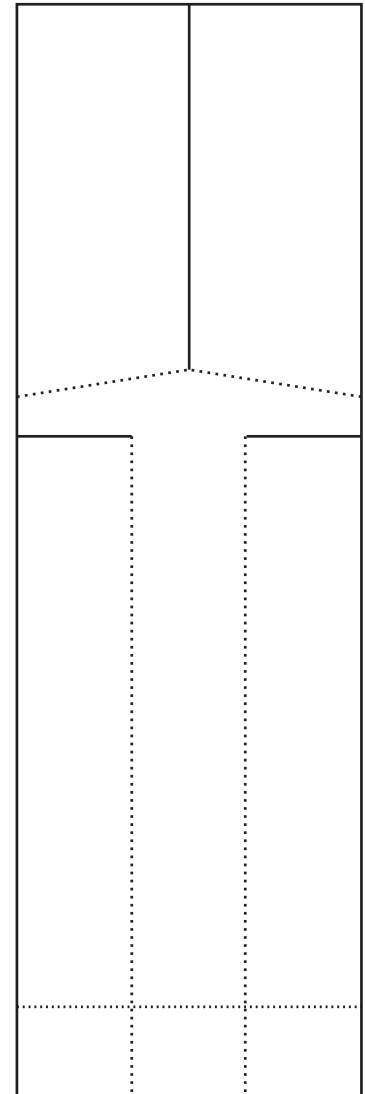
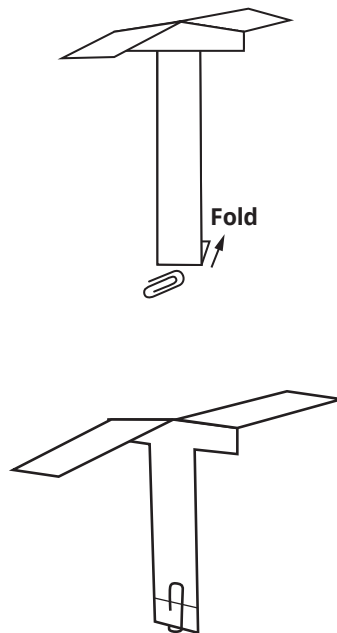
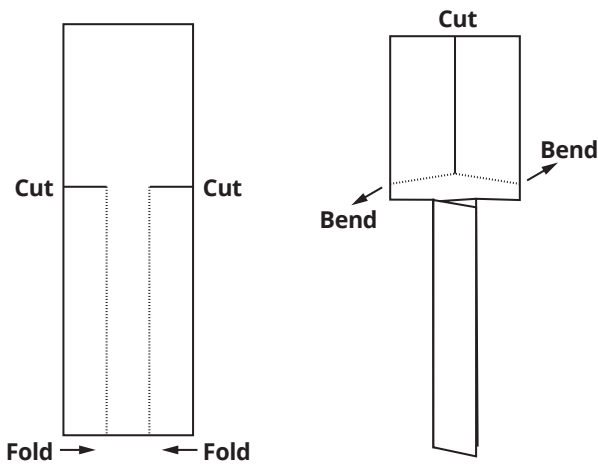

Activity Time

15 minutes

Materials

- Scissors
- Small paper clip



CONNECT WITH US



PLUM LANDING is produced
by WGBH Boston

MAJOR FUNDING



Major Funding is provided by the National Science
Foundation and The Kendeda Fund: furthering the
values that contribute to a healthy planet

hoja para repartir

Lanzasemillas



Exploramos tu mundo,
una misión a la vez
pbskids.org/plumlanding

¿De qué trata esta actividad?

¿Cómo esparcen sus semillas las plantas? Hagan un modelo y pongan a prueba una estrategia poderosa: vainas de semillas que explotan.

Megaconcepto científico: Las plantas no pueden ir por su cuenta de un sitio a otro. Dependen del viento, el agua, los animales y la fuerza explosiva para llevar sus semillas a sitios nuevos donde pueden germinar y prosperar.

Salgamos al aire libre

Cómo se hace un lanzasemillas

1. Corten y quítenle el cuello a un globo desinflado.
2. Corten la punta (el extremo opuesto al cuello) del globo.
3. Envuelvan el globo alrededor de un extremo del rollo de papel higiénico. Asegúrense de que quede bien apretado.
4. Con cinta adhesiva, pegue el globo en su sitio.

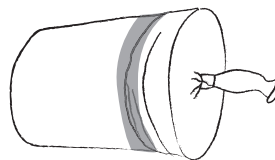

Cómo se prueba el lanzasemillas

1. Coloca unas semillas en el globo.
2. Estira el globo hasta el máximo que puedas. Suéltalo.
3. Organicen un concurso de lanzasemillas:
 - ¿A qué distancia puedes lanzar las semillas? ¿Puedes batir ese récord?
 - ¿Puedes saltar la distancia que recorren las semillas?
 - ¿Puedes correr más rápido de lo que vuelan las semillas?
 - ¿Cómo podrías aumentar las distancias que lanzas las semillas? (Semillas más livianas, globo que se superestire, lanzar en el sentido que sopla el viento, etc.)

Duración de la actividad

15 minutos

Materiales

Por persona

- Globo pequeño
- El tubo de un rollo de papel de baño o la mitad de tubo de toallas de papel
- Tijeras
- Rollo de cinta de enmascarar o de empaque
- Una media taza de semillas de alimento para aves (o pequeñas arvejas secas o trocitos de pasta triturada)

Dato genial

Ciertas vainas explosivas pueden lanzar sus semillas hasta 200 pies de distancia: más o menos el equivalente de dos canchas de baloncesto.

Diversiones familiares al aire libre con el app de Plum

Este app invita a las familias a salir al aire libre a explorar el mundo. Cada día, el app ofrece cinco misiones al aire libre que ponen a todos a pensar sobre la naturaleza y las ciencias que tenemos a nuestro alrededor. Disponible en inglés solamente.

Encuentren el app y más recursos divertidos en:
pbskids.org/plum.

Exploremos más

Explosiones en cámara lenta

Si tienen acceso a internet, busquen “vainas de semillas que explotan” y vean un video de vainas que explotan. El canal Smithsonian, por ejemplo, tiene un video increíble en cámara lenta en YouTube.



CONÉCTATE CON NOSOTROS



PLUM LANDING es una producción de WGBH Boston

CON AUSPICIO CLAVE DE



Auspicio clave de la National Science Foundation y el Kendeda Fund; promovemos los valores que aportan a tener un planeta saludable.

hoja para repartir

Semillas helicóptero



Exploramos tu mundo,
una misión a la vez
pbskids.org/plumlanding

¿De qué trata esta actividad?

¿Cómo esparcen sus semillas las plantas? Hagan una vaina de semillas con alas que gire y flote como un helicóptero.

Megaconcepto científico: Las plantas no pueden ir por su cuenta de un sitio a otro. Dependen del viento, el agua, los animales y la fuerza explosiva para llevar sus semillas a sitios nuevos donde pueden germinar y prosperar.

1. Corten en las líneas CONTINUAS.
2. Doblen en las líneas punteadas. Doblen un ala de semilla hacia adelante y la otra hacia atrás. Doblen las dos aletas laterales de abajo hacia el centro.
3. Doblen la aleta de abajo hacia arriba y pongan el gancho para sujetarla en su sitio.
4. Para lanzarlo, sujeten el helicóptero por el gancho y déjenlo caer.

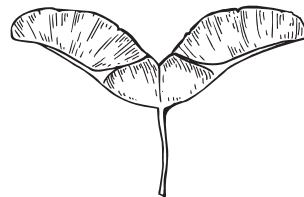

Semilla de arce

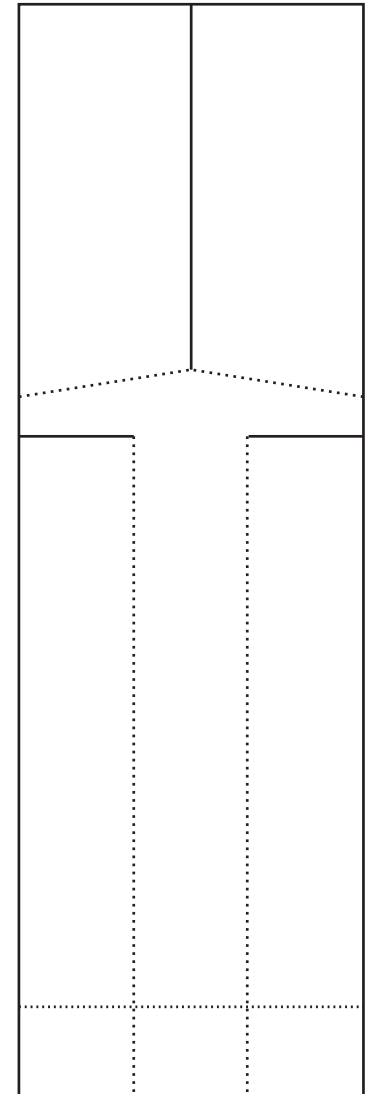
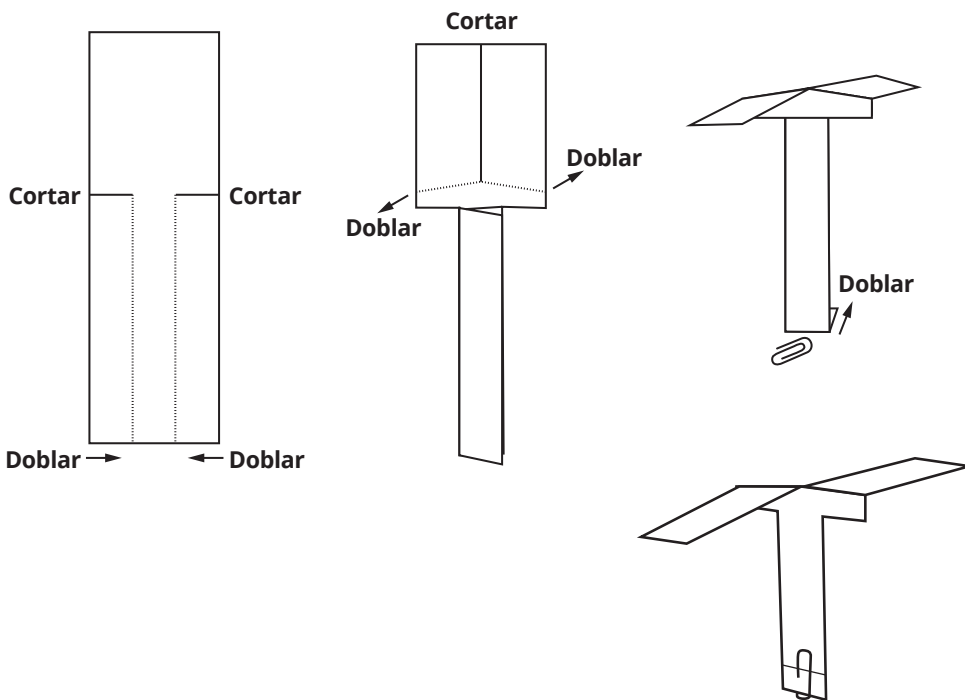

Duración de la actividad

15 minutos

Materiales

- Tijeras
- Pequeño gancho sujetapapeles



CONÉCTATE CON NOSOTROS



PLUM LANDING es una
producción de WGBH Boston

CON AUSPICIO
CLAVE DE



Auspicio clave de la National Science Foundation
y el Kendeda Fund: promovemos los valores que
aportan a tener un planeta saludable.

Earth's Gifts – Natural Resources

A natural resource is something in nature that people use to make or do things. Water, trees and plants, rocks and soil, wind, and fossil fuels are all examples of natural resources. We need to protect and use them wisely. What can be made or done with natural resources?

Directions:

1. Cut out the picture cards and sentence strips on the following pages.
2. Cut out the mini-book cover and pages.
3. Spread out the four mini-book pages. Glue a sentence strip to the top of each one.
4. Spread out the picture cards. Match them to the sentence strips on each page and glue them in the small boxes.
5. Draw one more picture on each page of something that can be made or done with that natural resource.
6. Staple your pages to the cover. Read your book!

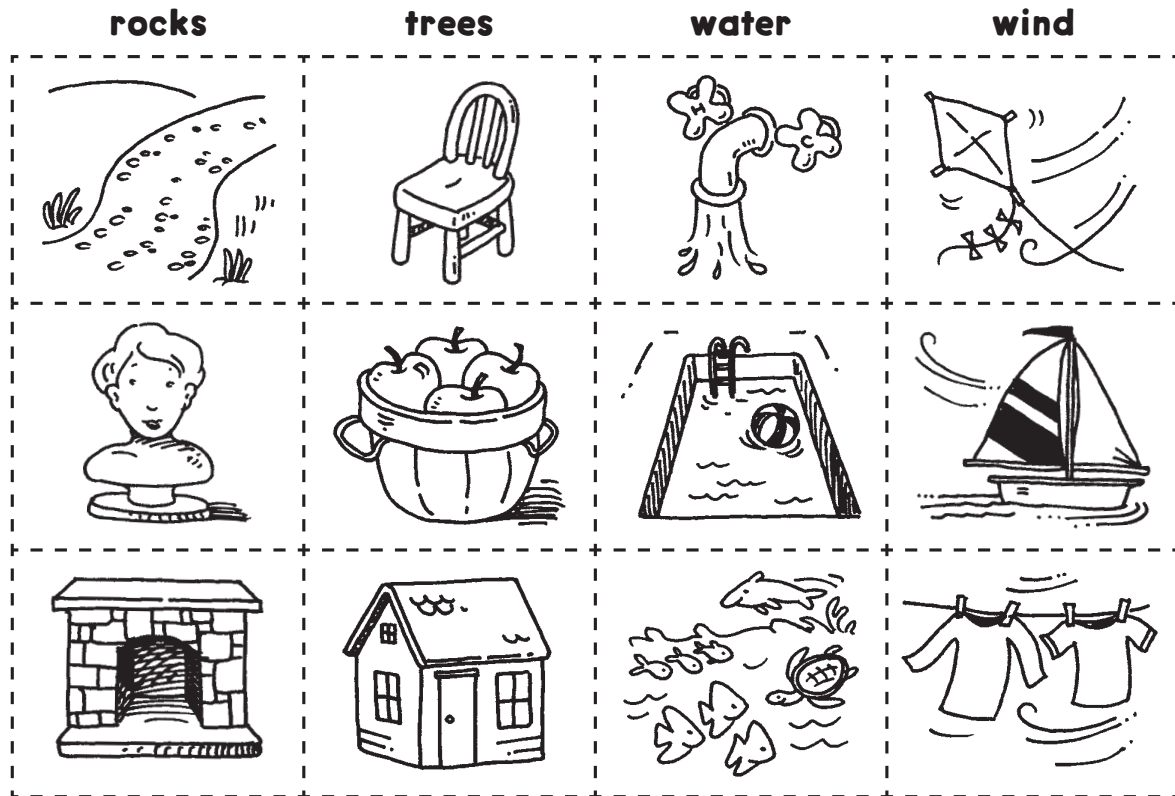

Earth gives us rocks for many things.



Earth gives us trees for many things.



Earth gives us water for many things.



Earth gives us wind for many things.



Earth's Gifts



by _____

Draw one more thing.

Draw one more thing.



Draw one more thing.

Draw one more thing.

Draw one more thing.

ESL at Home Gr. K-2 Weeks 5-6

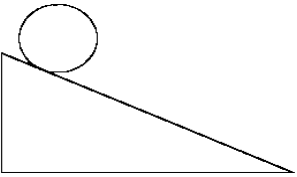











Use notebook paper to complete these activities. Do one each day!

Monday	Tuesday	Wednesday	Thursday	Friday
<p>Who is your favorite book or movie character? Write or draw what would happen if you met them in real life.</p>	<p>Look at the food in your home. Create a silly pretend menu for lunch. Example: Cheez-it and syrup sandwich with tuna fish juice.</p>	<p>Can you unscramble these animal names?</p> <p>caro rwmo cnaotu rumle</p>	<p>Write or draw a list of your family's favorite foods.</p> 	<p>Create your own superhero. Draw and label a costume and superpowers.</p>
Monday	Tuesday	Wednesday	Thursday	Friday
<p>Use boxes or books to create a ramp. Find five things to roll down the ramp.</p> 	<p>What is in your neighborhood? Draw and label a map of the homes and streets around you.</p>	<p>Take a walk in your neighborhood. Count the number of doors and windows you see.</p>	<p>Tally the shoes in your house. Who has the most? Who has the least?</p> 	<p>Choose two animals, like a horse and an alligator. Imagine what they would look like if they were put together. Draw it!</p>

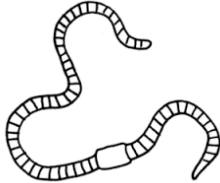
Name: _____

Celebrate Earth Day (April 22): Nature Walk

Directions: Check off the items you find on your walk.

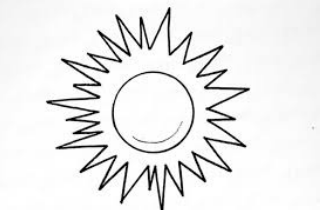
<input type="checkbox"/> dirt 	<input type="checkbox"/> acorn 	<input type="checkbox"/> grass 
<input type="checkbox"/> leaf 	<input type="checkbox"/> flower 	<input type="checkbox"/> tree 
<input type="checkbox"/> bird 	<input type="checkbox"/> worm 	<input type="checkbox"/> ant 
<input type="checkbox"/> dog 	<input type="checkbox"/> butterfly 	<input type="checkbox"/> squirrel 
<input type="checkbox"/> bee 	<input type="checkbox"/> sun 	<input type="checkbox"/> cloud 